

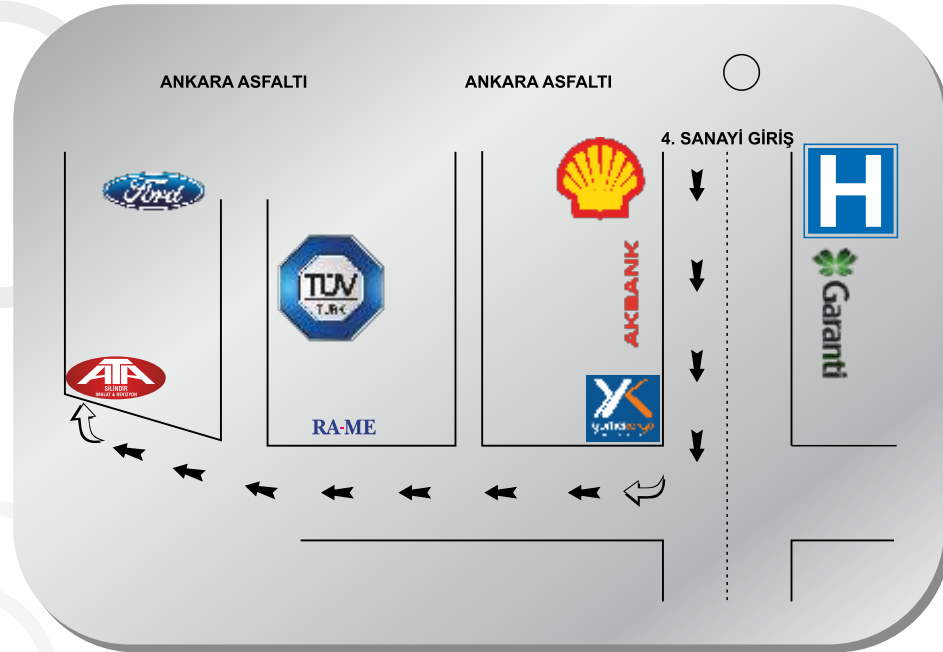

# ATA



129/24 Sokak No:6/C Naldöken Mah. 4. Sanayi Sitesi / Bornova - İZMİR  
Tel: 0 (232) 375 44 33 Fax: 0 (232) 375 44 43

CEKA 0 232 375 71 71



**ATA HİDROLİK SİLİNDİR MAKİNA  
İMALAT SAN. VE TİC. LTD. ŞTİ.**



*Sektördeki 10 yıllık deneyim yeni bir çatı altında...*

info@atahidrolik.com.tr

www.atahidrolik.com.tr

## HİDROLİK SİLİNDİR İMALATI ve REVİZYONUNDA ÇÖZÜM ORTAĞINIZ...



Ata Hidrolik Silindir Makinaları İmalat San. ve Tic. Ltd. Şti. 2012 yılında alanında uzman, tecrübeli ve yenilikçi bir ekip tarafından kuruldu.

Ata Hidrolik kaliteden ödün vermeyerek büyümeye ve kendini geliştirmeye devam etmektedir. Üretim, satış ve satış sonrası destek alanı ile sektörün lider firmalarındandır.

Temel ilkerimiz hatasız üretim, zamanında teslimat ve müşteri memnuniyetidir.

Üretim süreci planlamasını yaparken hidrolik silindirlere kaynaklı problemleri önceden ön görüp oluşabilecek arızalara karşı teslimat öncesi ürünlerimizi test etmekteyiz.

Saygılarımızla

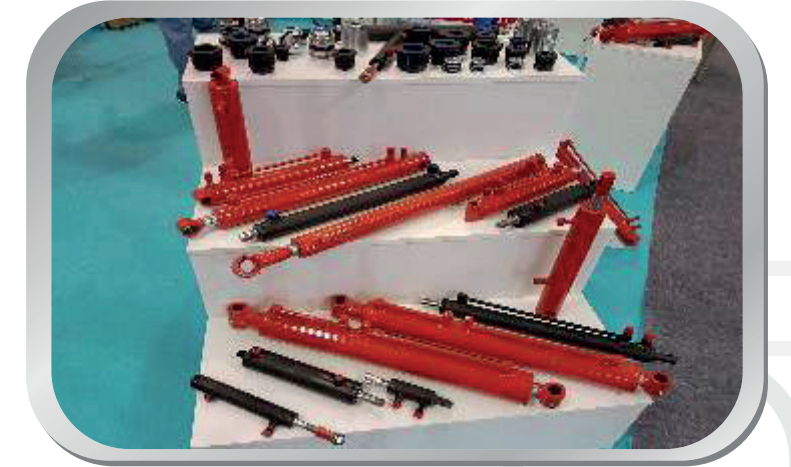

## TARIM SEKTÖRÜ;

- \* Goble silindirleri
- \* Kültüvatör silindirleri
- \* Mibzer silindirleri
- \* Çapa silindirleri
- \* Yem karma makinası silindirleri
- \* Gübre küreme silindirleri



## FAALİYET ALANLARIMIZ;

- \* Mobil sektöre ait hidrolik silindirlerin;
- \* Endüstriyel tip hidrolik silindirlerin;
- \* Tarım makinalarına ait hidrolik silindirlerin;
- \* Paslanmaz gıda makinaları ve tekne silindirlerinin imalat ve revizyonu.
- \* H8 toleransında honlanmış silindir boruları;
- \* H9 toleransında soğuk çekme silindir boruları;
- \* Sert krom kaplı taşlanmış silindir milleri;
- \* Sert krom kaplı indüksiyonla sertleştirilmiş silindir milleri;
- \* Hidrolik devre boruları;
- \* Hidrolik silindir piston ve boğaz kepleri satışı.



Bizim işimiz iyi tasarlanmış ve üretilmiş hidrolik silindirlerle iş programınızı olabildiğince problemsiz hale getirmektir.

## MOBİL SEKTÖR;

- \* İş makinası silindirleri
- \* Forklift silindirleri
- \* Vinç silindirleri
- \* Araç üstü ekipman silindirleri
- \* Hurda polip silindirleri



Her marka ve model iş makinasında kullanılan hidrolik silindirler orjinaline uygun olarak imal & revize edilmektedir.



Mobil sektöre ait hidrolik silindirlerde hatasız ve hızlı revizyon ile iş gücü kayıplarınızı minimuma indiriyoruz.

## ENDÜSTRİYEL SİLİNDİRLER;

- \* Hidrolik pres silindirleri
- \* Kalıp silindirleri
- \* Yükseltme platformları ve hidrolik rampa silindirleri
- \* Hurda presi silindirleri
- \* Demir - çelik endüstrisi, haddehane silindirleri



- \* Ağır çalışma şartlarına uygun;
- \* Yüksek sıcaklığa dayanıklı;
- \* Yüksek çalışma basıncına sahip her tip özel ve ISO/CETOP normuna uygun hidrolik silindir imalatı...



Hidrolik silindirlerden kaynaklı problemlerin ve duruşların büyük mali kayıplara ve sorunlara yol açabileceğinin bilincindeyiz; bu yüzden imalat sürecimizi büyük bir titizlikle planlayıp yürütüyoruz.

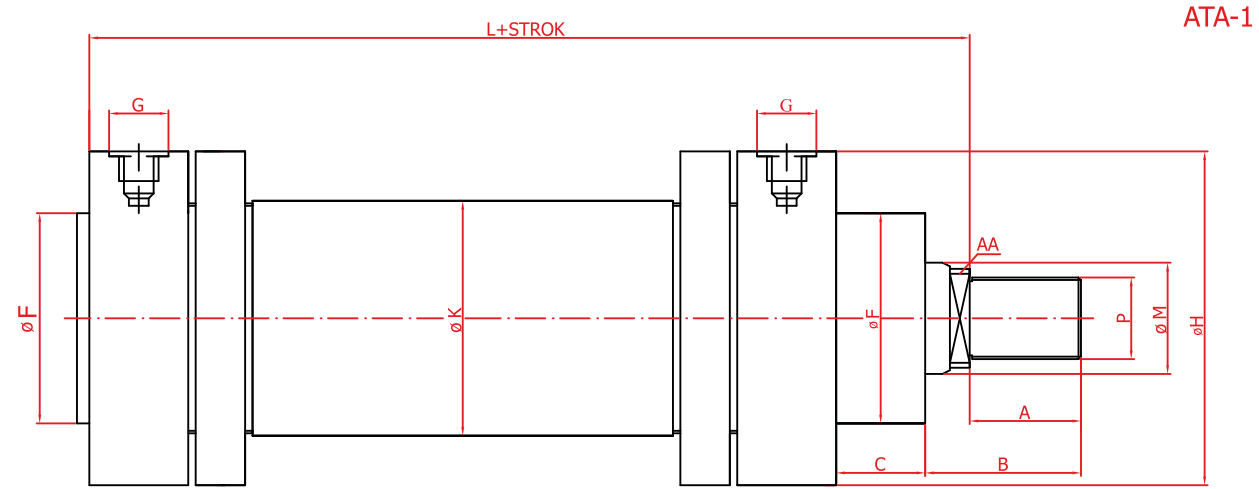

ATA-1

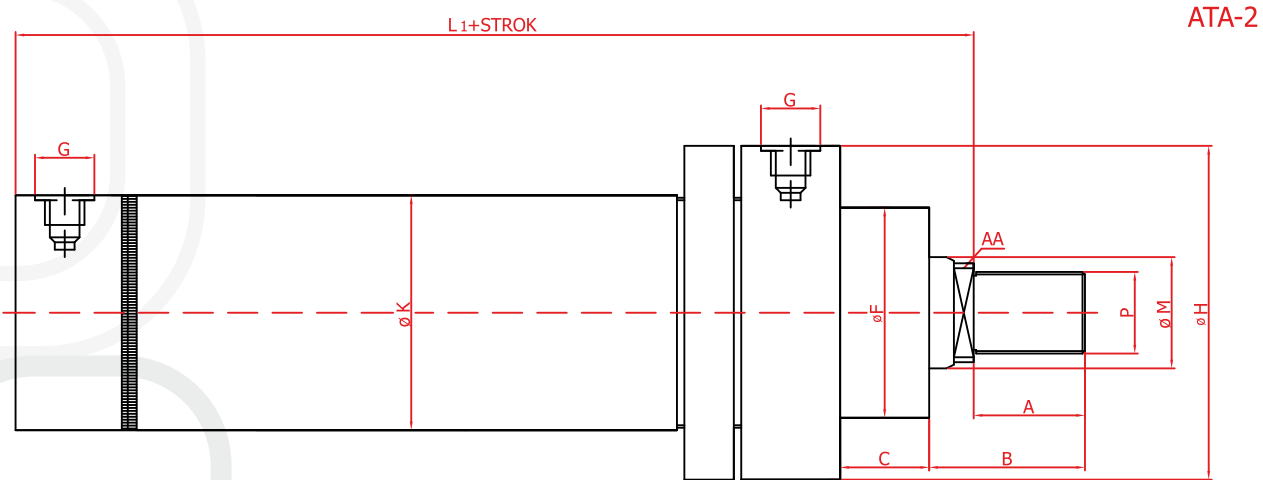

ATA-2

PİSTON	ø32	ø40	ø50	ø63	ø80	ø100	ø125	ø140	ø160	ø180	ø200
MİL (M)	18/22	22/28	28/36	36/45	45/56	56/70	70/80	80/90	90/100	100/110	110/120
PASO (P)	M14X1.5	M16X1.5	M20X1.5	M27X2.0	M33X2.0	M42X2.0	M48X2.0	M56X2.0	M64X3.0	M72X3.0	M80X3.0
	M16X1.5	M20X1.5	M27X2.0	M33X2.0	M42X2.0	M48X2.0	M56X2.0	M64X3.0	M72X3.0	M80X3.0	M85X3.0
AA	14/17	17/22	22/30	30/36	36/45	45/60	60/68	68/75	75/85	85/95	95/105
A	18/22	22/28	28/36	36/45	45/56	56/63	63/75	75/85	85/90	90/95	95/100
B	31/35	35/41	42/50	52/61	63/74	76/83	86/98	100/110	110/115	120/125	125/130
C	19	19	24	29	36	37	37	40	41	45	45
K	40	50	60	75	95	115	150	165	190	210	245
F	40	50	60	70	85	106	132	145	160	185	200
G	R1/4"	R3/8"	R1/2"	R1/2"	R1/2"	R3/4"	R3/4"	R3/4"	R1"	R1"	R1"
H	68	78	98	108	135	158	186	210	240	255	305
L	170	190	205	224	250	300	328	360	370	425	450
L1	165	185	198	214	238	286	310	330	350	405	420

ISO 6020/1 Cetop R58 H Standart Cetop Silindirler - Çalışma Basıncı : 160 Bar

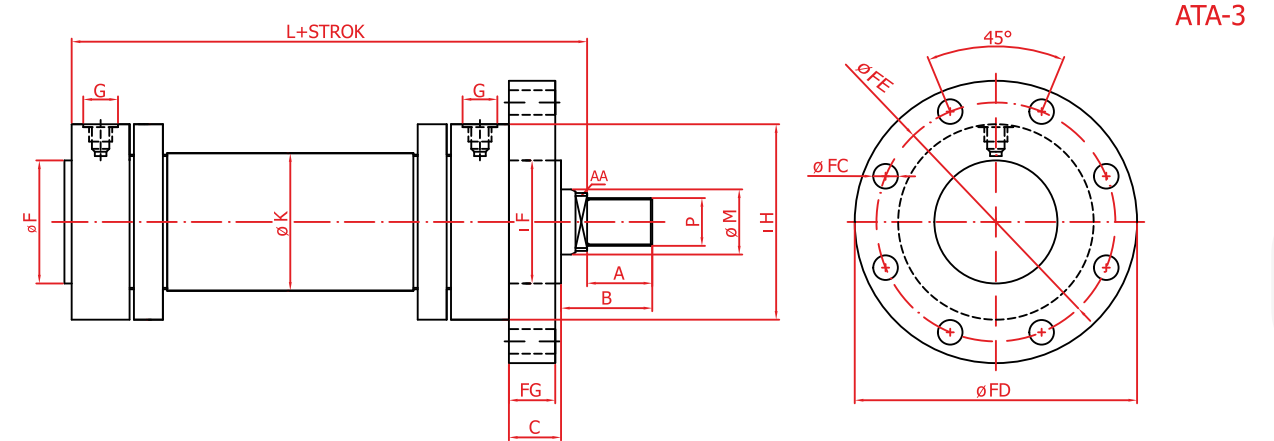

ATA-3

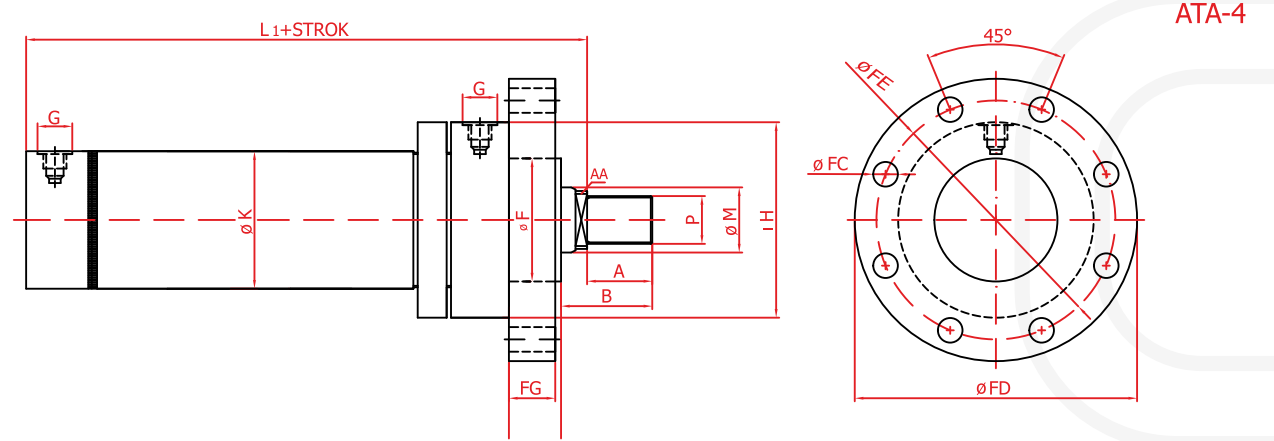

ATA-4

PİSTON	ø32	ø40	ø50	ø63	ø80	ø100	ø125	ø140	ø160	ø180	ø200
MİL (M)	18/22	22/28	28/36	36/45	45/56	56/70	70/80	80/90	90/100	100/110	110/120
PASO (P)	M14X1.5	M16X1.5	M20X1.5	M27X2.0	M33X2.0	M42X2.0	M48X2.0	M56X2.0	M64X3.0	M72X3.0	M80X3.0
	M16X1.5	M20X1.5	M27X2.0	M33X2.0	M42X2.0	M48X2.0	M56X2.0	M64X3.0	M72X3.0	M80X3.0	M85X3.0
AA	14/17	17/22	22/30	30/36	36/45	45/60	60/68	68/75	75/85	85/95	95/105
A	18/22	22/28	28/36	36/45	45/56	56/63	63/75	75/85	85/90	90/95	95/100
B	31/35	35/41	42/50	52/61	63/74	76/83	86/98	100/110	110/115	120/125	125/130
C	19	19	24	29	36	37	37	40	41	45	45
K	40	50	60	75	95	115	150	165	190	210	245
F	40	50	60	70	85	106	132	145	160	185	200
FC	9	9	11	13	17	22	22	22	22	26	26
FD	110	125	148	170	195	238	272	296	316	365	385
FE	92	106	126	145	165	200	235	260	280	320	340
FG	16	16	20	25	32	32	32	35	36	40	40
G	R1/4"	R3/8"	R1/2"	R1/2"	R1/2"	R3/4"	R3/4"	R3/4"	R1"	R1"	R1"
H	68	78	98	108	135	158	186	210	240	255	305
L	170	190	205	224	250	300	328	360	370	425	450
L1	165	185	198	214	238	286	310	330	350	405	420

ISO 6020/1 Cetop R58 H Standart Cetop Silindirler - Çalışma Basıncı : 160 Bar

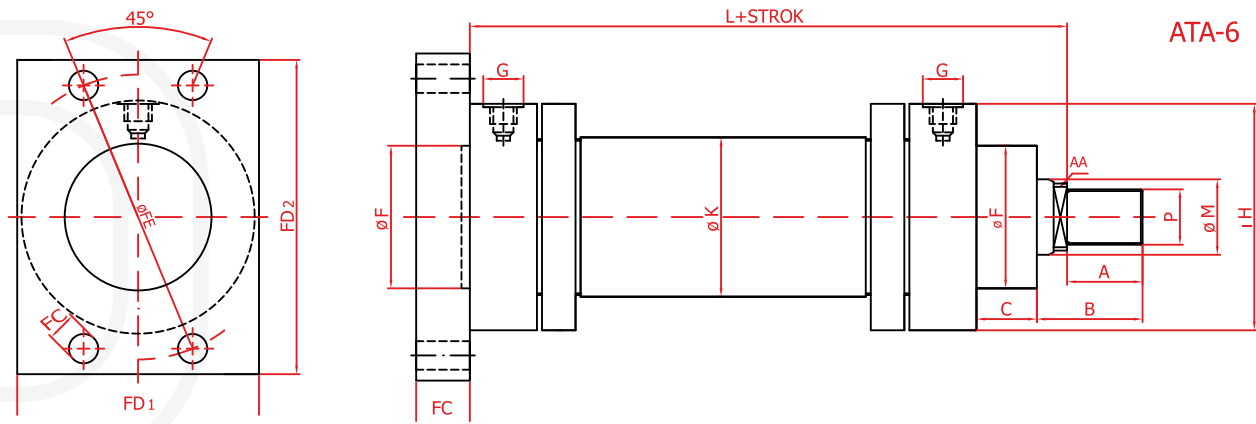
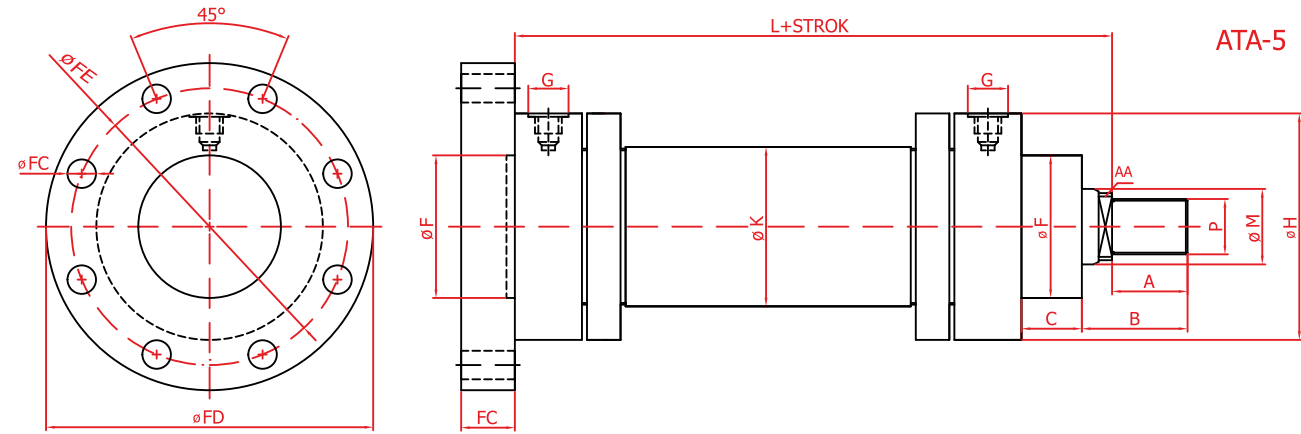

PİSTON	ø32	ø40	ø50	ø63	ø80	ø100	ø125	ø140	ø160	ø180	ø200
MİL (M)	18/22	22/28	28/36	36/45	45/56	56/70	70/80	80/90	90/100	100/110	110/120
PASO (P)	M14X1.5	M16X1.5	M20X1.5	M27X2.0	M33X2.0	M42X2.0	M48X2.0	M56X2.0	M64X3.0	M72X3.0	M80X3.0
	M16X1.5	M20X1.5	M27X2.0	M33X2.0	M42X2.0	M48X2.0	M56X2.0	M64X3.0	M72X3.0	M80X3.0	M85X3.0
AA	14/17	17/22	22/30	30/36	36/45	45/60	60/68	68/75	75/85	85/95	95/105
A	18/22	22/28	28/36	36/45	45/56	56/63	63/75	75/85	85/90	90/95	95/100
B	31/35	35/41	42/50	52/61	63/74	76/83	86/98	100/110	110/115	120/125	125/130
C	19	19	24	29	36	37	37	40	41	45	45
K	40	50	60	75	95	115	150	165	190	210	245
F	40	50	60	70	85	106	132	145	160	185	200
FC	9	9	11	13	17	22	22	22	22	26	26
FD	110	125	148	170	195	238	272	296	316	365	385
FD1	70	80	90	110	140	150	180				
FD2	105	115	140	160	182	220	252				
FE	92	106	126	145	165	200	235	260	280	320	340
FG	16	16	20	25	32	32	32	35	36	40	40
G	R1/4"	R3/8"	R1/2"	R1/2"	R1/2"	R3/4"	R3/4"	R3/4"	R1"	R1"	R1"
H	68	78	98	108	135	158	186	210	240	255	305
L	170	190	205	224	250	300	328	360	370	425	450
L1	165	185	198	214	238	286	310	330	350	405	420

ISO 6020/1 Cetop R58 H Standart Cetop Silindirler - Çalışma Basıncı : 160 Bar

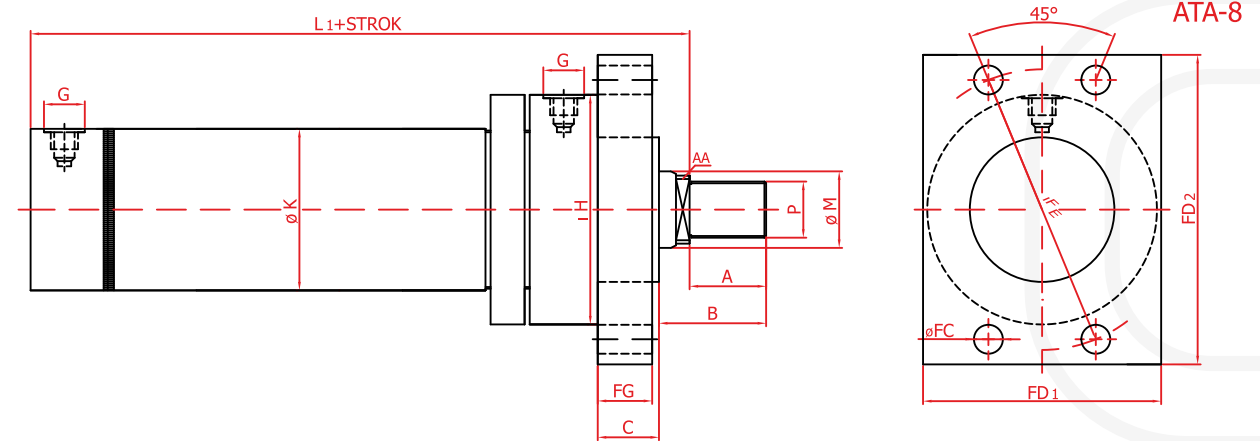
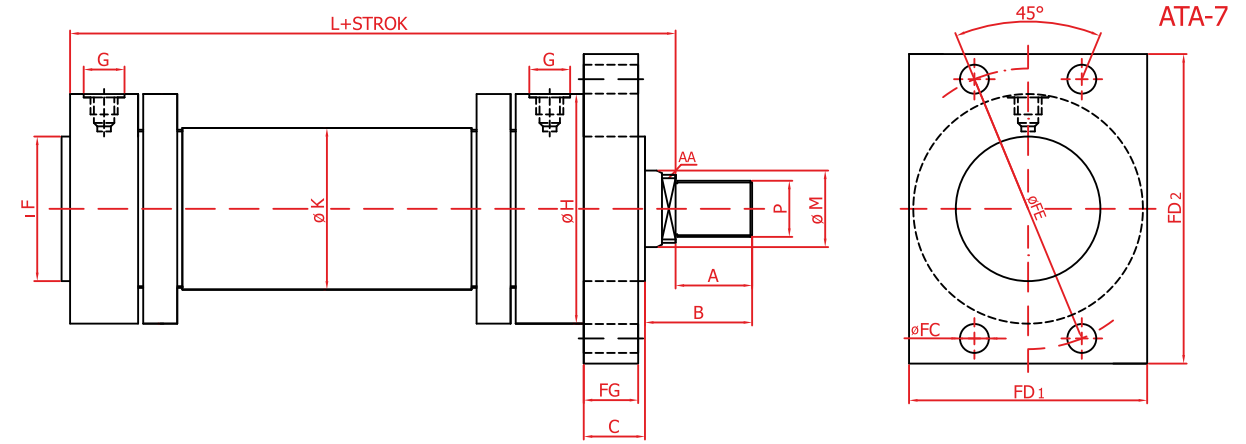

PİSTON	ø32	ø40	ø50	ø63	ø80	ø100	ø125	ø140	ø160	ø180	ø200
M (MİL)	18/22	22/28	28/36	36/45	45/56	56/70	70/80	80/90	90/100	100/110	110/120
PASO (P)	M14X1.5	M16X1.5	M20X1.5	M27X2.0	M33X2.0	M42X2.0	M48X2.0	M56X2.0	M64X3.0	M72X3.0	M80X3.0
	M16X1.5	M20X1.5	M27X2.0	M33X2.0	M42X2.0	M48X2.0	M56X2.0	M64X3.0	M72X3.0	M80X3.0	M85X3.0
AA	14/17	17/22	22/30	30/36	36/45	45/60	60/68	68/75	75/85	85/95	95/105
A	18/22	22/28	28/36	36/45	45/56	56/63	63/75	75/85	85/90	90/95	95/100
B	31/35	35/41	42/50	52/61	63/74	76/83	86/98	100/110	110/115	120/125	125/130
C	19	19	24	29	36	37	37	40	41	45	45
K	40	50	60	75	95	115	150	165	190	210	245
F	40	50	60	70	85	106	132	145	160	185	200
FC	9	9	11	13	17	22	22	22	22	26	26
FD	110	125	148	170	195	238	272	296	316	365	385
FD1	70	80	90	110	140	150	180				
FD2	105	115	140	160	182	220	252				
FE	92	106	126	145	165	200	235	260	280	320	340
FG	16	16	20	25	32	32	32	35	36	40	40
G	R1/4"	R3/8"	R1/2"	R1/2"	R1/2"	R3/4"	R3/4"	R3/4"	R1"	R1"	R1"
H	68	78	98	108	135	158	186	210	240	255	305
L	170	190	205	224	250	300	328	360	370	425	450
L1	165	185	198	214	238	286	310	330	350	405	420

ISO 6020/1 Cetop R58 H Standart Cetop Silindirler - Çalışma Basıncı : 160 Bar

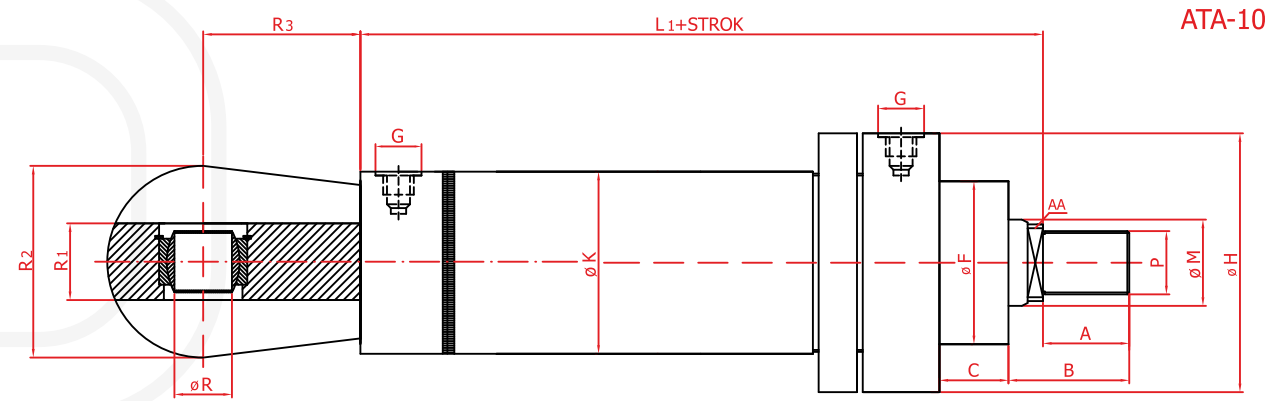
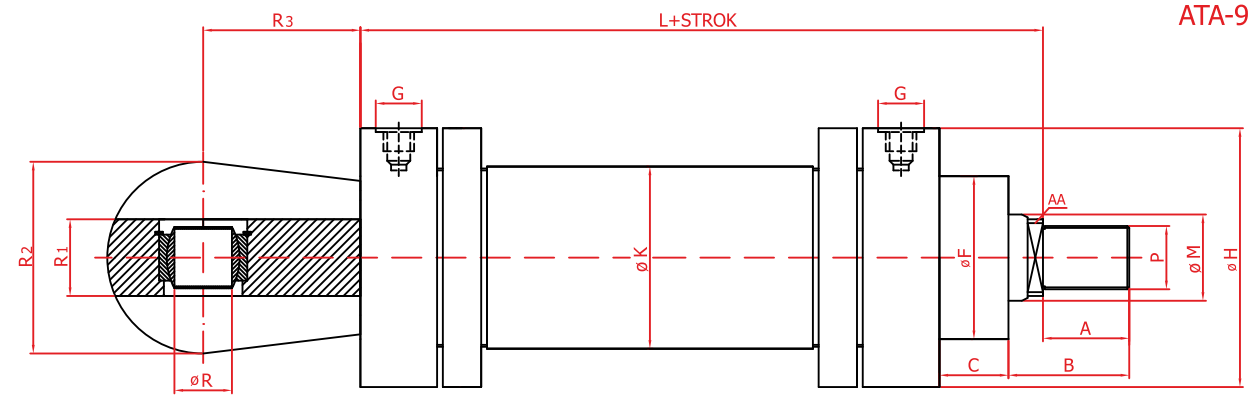

PİSTON	ø32	ø40	ø50	ø63	ø80	ø100	ø125	ø140	ø160	ø180	ø200
MİL (M)	18/22	22/28	28/36	36/45	45/56	56/70	70/80	80/90	90/100	100/110	110/120
PASO (P)	M14X1.5	M16X1.5	M20X1.5	M27X2.0	M33X2.0	M42X2.0	M48X2.0	M56X2.0	M64X3.0	M72X3.0	M80X3.0
	M16X1.5	M20X1.5	M27X2.0	M33X2.0	M42X2.0	M48X2.0	M56X2.0	M64X3.0	M72X3.0	M80X3.0	M85X3.0
AA	14/17	17/22	22/30	30/36	36/45	45/60	60/68	68/75	75/85	85/95	95/105
A	18/22	22/28	28/36	36/45	45/56	56/63	63/75	75/85	85/90	90/95	95/100
B	31/35	35/41	42/50	52/61	63/74	76/83	86/98	100/110	110/115	120/125	125/130
C	19	19	24	29	36	37	40	41	45	45	45
K	40	50	60	75	95	115	150	165	190	210	245
F	40	50	60	70	85	106	132	145	160	185	200
G	R1/4"	R3/8"	R1/2"	R1/2"	R1/2"	R3/4"	R3/4"	R3/4"	R1"	R1"	R1"
H	68	78	98	108	135	158	186	210	240	255	305
L	170	190	205	224	250	300	328	360	370	425	450
L1	165	185	198	214	238	286	310	330	350	405	420
R	16	20	25	30	40	50	60	70	80	90	100
R1	16	20	25	30	40	50	60	70	80	90	100
R2	40	50	64	80	100	126	142	170	180	204	224
R3	20	25	32	40	82	95	103	125	135	155	165

ISO 6020/1 Cetop R58 H Standart Cetop Silindirler - Çalışma Basıncı : 160 Bar

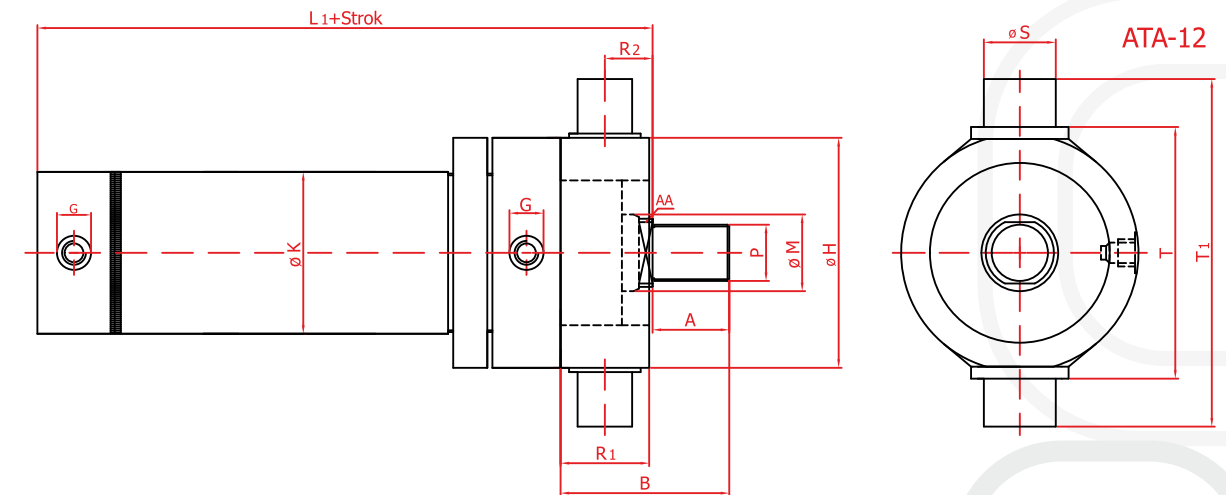
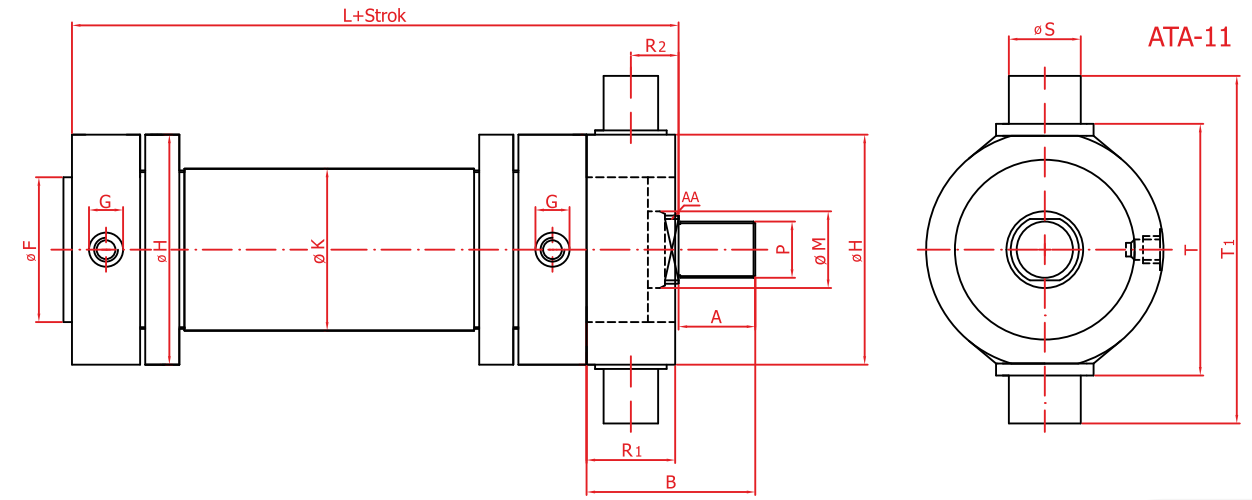

PİSTON	ø32	ø40	ø50	ø63	ø80	ø100	ø125	ø140	ø160	ø180	ø200
MİL (M)	18/22	22/28	28/36	36/45	45/56	56/70	70/80	80/90	90/100	100/110	110/120
PASO (P)	M14X1.5	M16X1.5	M20X1.5	M27X2.0	M33X2.0	M42X2.0	M48X2.0	M56X2.0	M64X3.0	M72X3.0	M80X3.0
	M16X1.5	M20X1.5	M27X2.0	M33X2.0	M42X2.0	M48X2.0	M56X2.0	M64X3.0	M72X3.0	M80X3.0	M85X3.0
AA	14/17	17/22	22/30	30/36	36/45	45/60	60/68	68/75	75/85	85/95	95/105
A	18/22	22/28	28/36	36/45	45/56	56/63	63/75	75/85	85/90	90/95	95/100
B	31/35	35/41	42/50	52/61	63/74	76/83	86/98	100/110	110/115	120/125	125/130
K	40	50	60	75	95	115	150	165	190	210	245
F	40	50	60	70	85	106	132	145	160	185	200
G	R1/4"	R3/8"	R1/2"	R1/2"	R1/2"	R3/4"	R3/4"	R3/4"	R1"	R1"	R1"
H	68	78	98	108	135	158	186	210	240	255	305
L	170	190	205	224	250	300	328	360	370	425	450
L1	165	185	198	214	238	286	310	330	350	405	420
T	75	90	105	120	140	165	195	220	250	275	315
T1	99	122	145	170	204	245	295	332	376	415	475
R1	30	30	36	42	52	62	76	90	96	110	120
R2	47/43	47/41	56/48	66/57	80/69	88/81	98/86	110/100	114/109	130/125	135/130
S	16	20	25	30	40	50	63	70	80	90	100

ISO 6020/1 Cetop R58 H Standart Cetop Silindirler - Çalışma Basıncı : 160 Bar

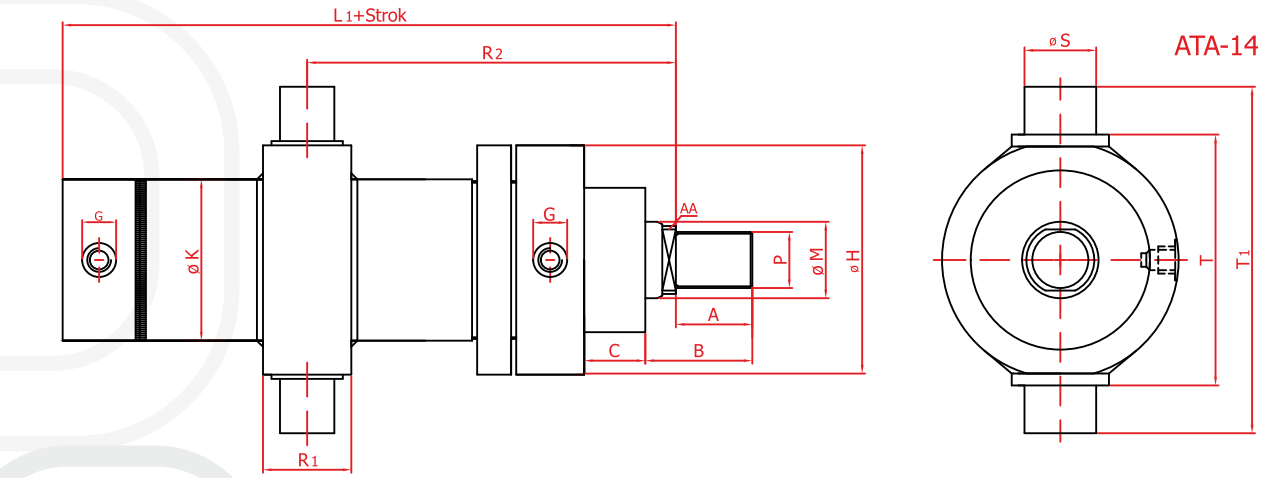
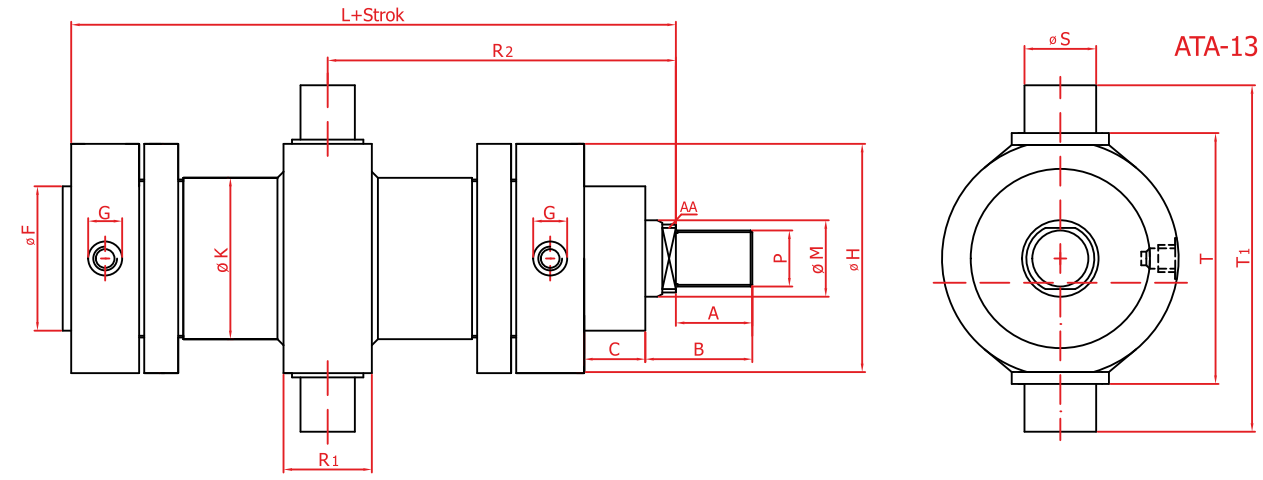

PİSTON	ø32	ø40	ø50	ø63	ø80	ø100	ø125	ø140	ø160	ø180	ø200
MİL (M)	18/22	22/28	28/36	36/45	45/56	56/70	70/80	80/90	90/100	100/110	110/120
PASO (P)	M14x1.5	M16x1.5	M20x1.5	M27x2.0	M33x2.0	M42x2.0	M48x2.0	M56x2.0	M64x3.0	M72x3.0	M80x3.0
	M16x1.5	M20x1.5	M27x2.0	M33x2.0	M42x2.0	M48x2.0	M56x2.0	M64x3.0	M72x3.0	M80x3.0	M85x3.0
AA	14/17	17/22	22/30	30/36	36/45	45/60	60/68	68/75	75/85	85/95	95/105
A	18/22	22/28	28/36	36/45	45/56	56/63	63/75	75/85	85/90	90/95	95/100
B	31/35	35/41	42/50	52/61	63/74	76/83	86/98	100/110	110/115	120/125	125/130
C	19	19	24	29	36	37	37	40	41	45	45
K	40	50	60	75	95	115	150	165	190	210	245
F	40	50	60	70	85	106	132	145	160	185	200
G	R1/4"	R3/8"	R1/2"	R1/2"	R1/2"	R3/4"	R3/4"	R3/4"	R1"	R1"	R1"
H	68	78	98	108	135	158	186	210	240	255	305
L	170	190	205	224	250	300	328	360	370	425	450
L1	165	185	198	214	238	286	310	330	350	405	420
T	75	90	105	120	140	165	195	220	250	275	315
T1	99	122	145	170	204	245	295	332	376	415	475
R1	32	36	45	55	65	70	90	100	110	120	130
R2	108	130	139	159	169	210	238	265	271	313	355
S	16	20	25	30	40	50	63	70	80	90	100

ISO 6020/1 Cetop R5 H Standart Cetop Silindirler - Çalışma Basıncı : 160 Bar

## SİLİNDİR BAĞLANTI PARÇALARI

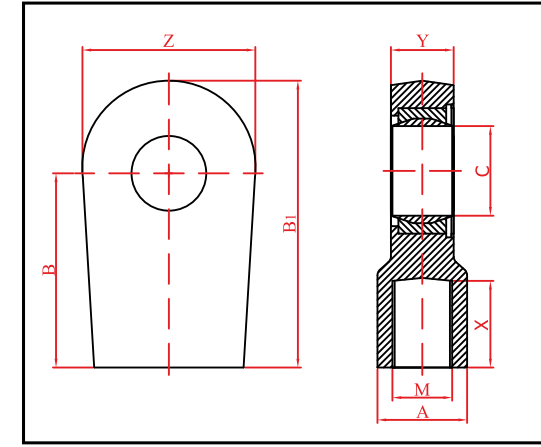

### ÖN MAFSAL

PİSTON	D	M	A	B	B1	C	X	Y	Z
ø32	18	M14x1.5	21	44	64	16	19	13	40
ø40	22	M16x1.5	25	52	77	20	23	17	47
ø50	28	M20x1.5	30	65	96	25	29	21	58
ø63	36	M27x2.0	38	80	118	30	37	27	70
ø80	45	M33x2.0	47	97	145.5	40	46	32	89
ø100	56	M42x2.0	58	120	179	50	57	40	108
ø125	70	M48x2.0	70	140	211	60	64	52	132
ø140	80	M56x2.0	80	160	245	70	76	57	155
ø160	90	M64x3.0	90	180	270	80	86	66	168
ø180	100	M72x3.0	100	195	296	90	91	72	185
ø200	110	M80x3.0	110	210	322	100	96	84	210

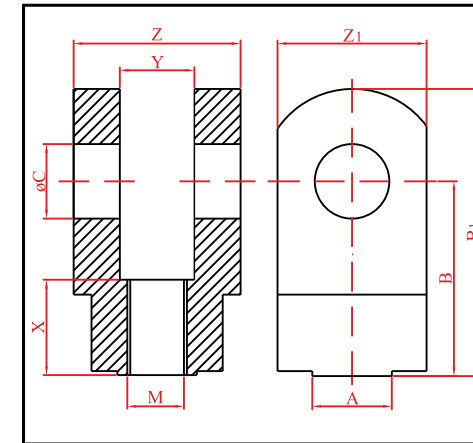

### ÇATAL BAĞLANTI

PİSTON	D	M	A	B	B1	C	X	Y	Z	Z1
ø32	18	M14x1.5	21	44	64	16	19	16	32	36
ø40	22	M16x1.5	25	52	77	20	23	20	40	45
ø50	28	M20x1.5	30	65	96	25	29	25	50	56
ø63	36	M27x2.0	38	80	118	30	37	32	65	70
ø80	45	M33x2.0	47	97	145.5	40	46	40	80	90
ø100	56	M42x2.0	58	120	179	50	57	50	100	110
ø125	70	M48x2.0	70	140	211	60	64	63	130	140
ø140	80	M56x2.0	80	160	245	70	76	70	145	155
ø160	90	M64x3.0	90	180	270	80	86	80	160	170
ø180	100	M72x3.0	100	195	296	90	91	90	180	190
ø200	110	M80x3.0	110	210	322	100	96	100	200	210

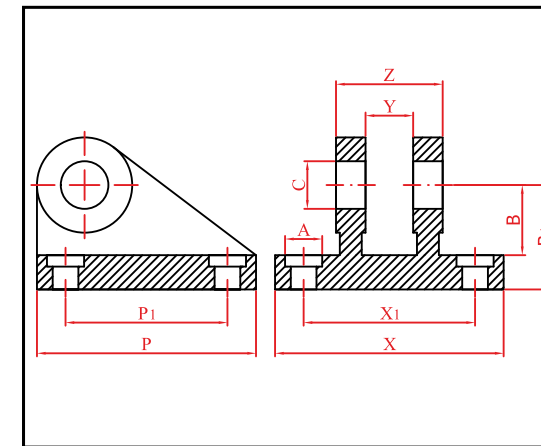

### AYAK BAĞLANTI

PİSTON	A	B	B1	C	P	P1	X	X1	Y	Z
ø32	11	27	40	16	80	55	90	65	16	36
ø40	11	30	45	20	95	70	100	75	20	45
ø50	13.5	37	55	25	115	85	120	90	25	56
ø63	17.5	43	65	30	145	110	145	110	30	70
ø80	22	52	76	40	170	125	185	140	40	90
ø100	26	65	95	50	200	150	215	165	50	110
ø125	33	75	112	60	230	170	270	210	60	140
ø140	33	90	133	70	255	190	290	230	70	155
ø160	39	95	140	80	280	210	320	250	80	170
ø180	39	105	160	90	310	230	350	280	90	190
ø200	39	117	182	100	340	260	380	310	100	210